

PUNCH Powerglide Strasbourg Research & Development Center June 2018



Summary

- 1 - Strasbourg Technical Center (STC)
- 2 - Design and Analysis (HRC)
- 3 - Team Innovation
- 4 - Test Facilities
- 5 - Software and Calibration
- 6 - Project Management
- 7 - Strasbourg Technical Center - Experience

Strasbourg Technical Center



Strasbourg Technical Center (STC)



The STC takes advantage of maximized synergies between multidisciplinary resources and maintains a close engineering relationship with Automotive manufacturers and suppliers around the world.

Office area :

- Max. capacity (seating) of 220 people
- Conference rooms, wireless access to internet
- Dedicated hosts to handle engineering data
- Internal Web server to share specific data.



Organization

- Project-Oriented Organization
- Operates as a Matrix
- Based on 3 Main Activities

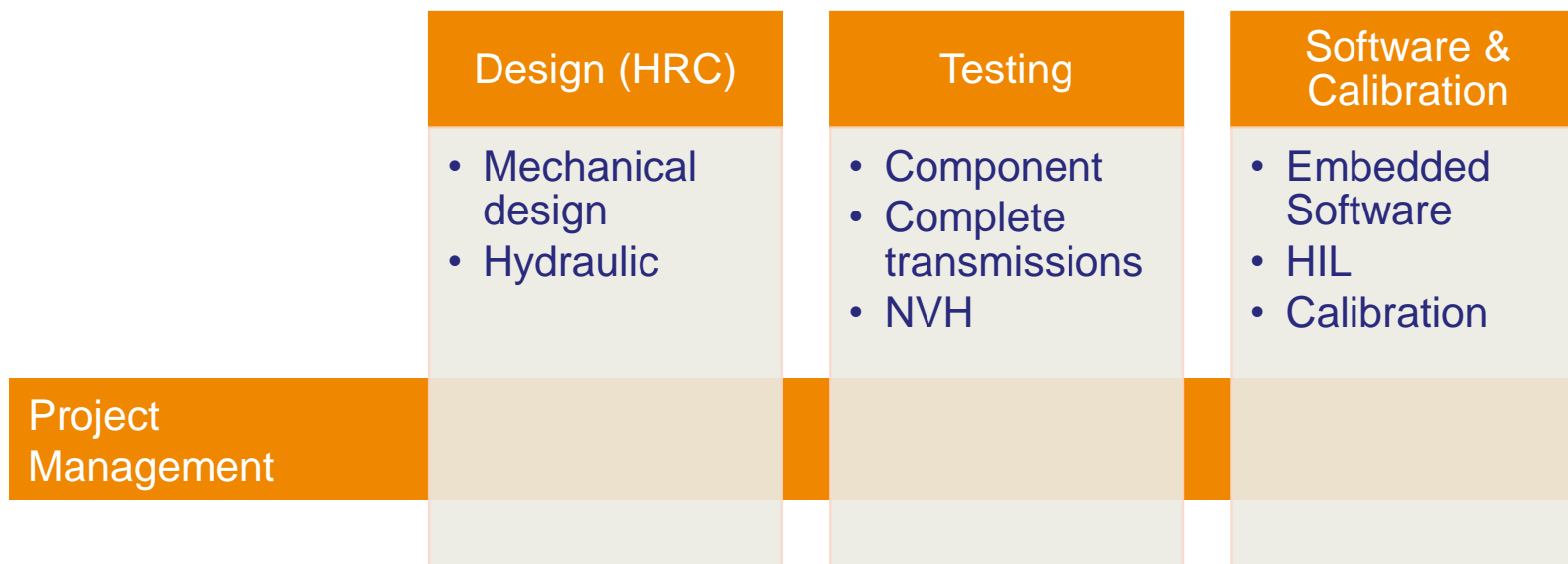

Strasbourg Technical Center (STC)

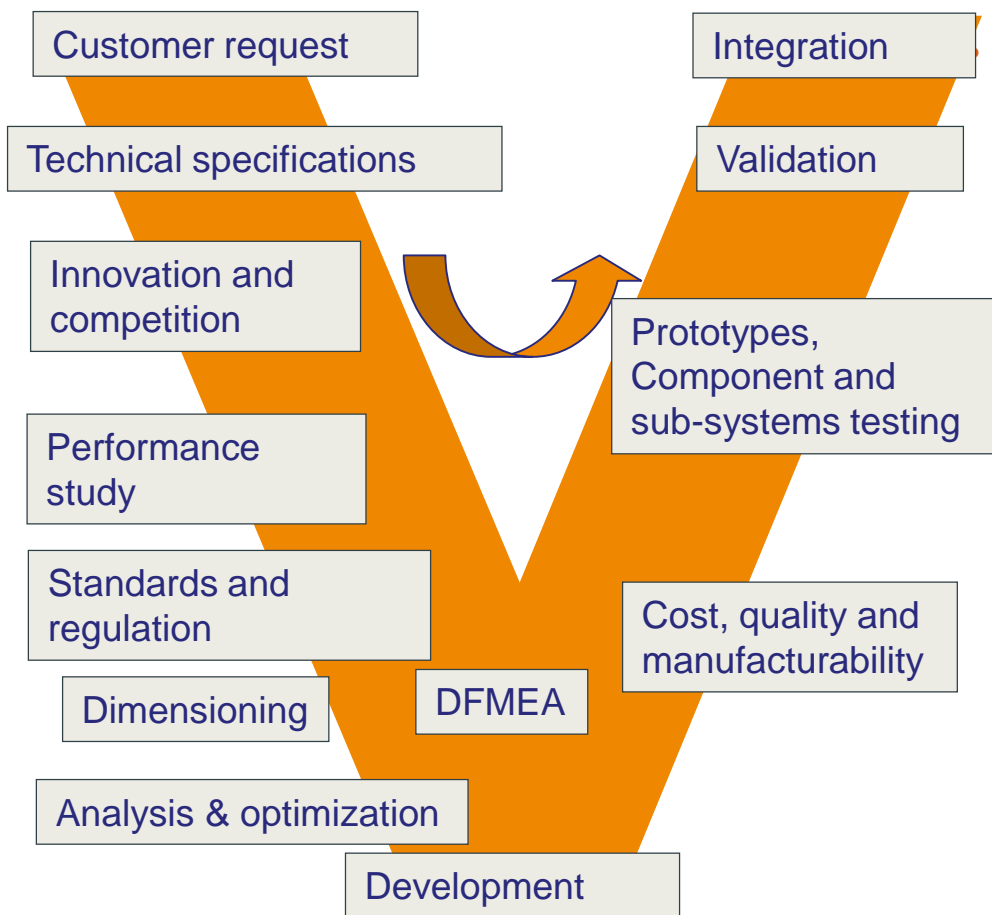

Multidisciplinary skills : Performing Technical support in design and innovation

- **Project management**, cross-functional coordination
- **Simultaneous engineering** with internal manufacturing (machining, assembly, foundry) and suppliers
- **Design of experiments** and trade-off studies
- **Failure modes effect analysis (FMEA)**
- **Duty cycle analysis** based on reliability assessment.

Design and Analysis (HRC)

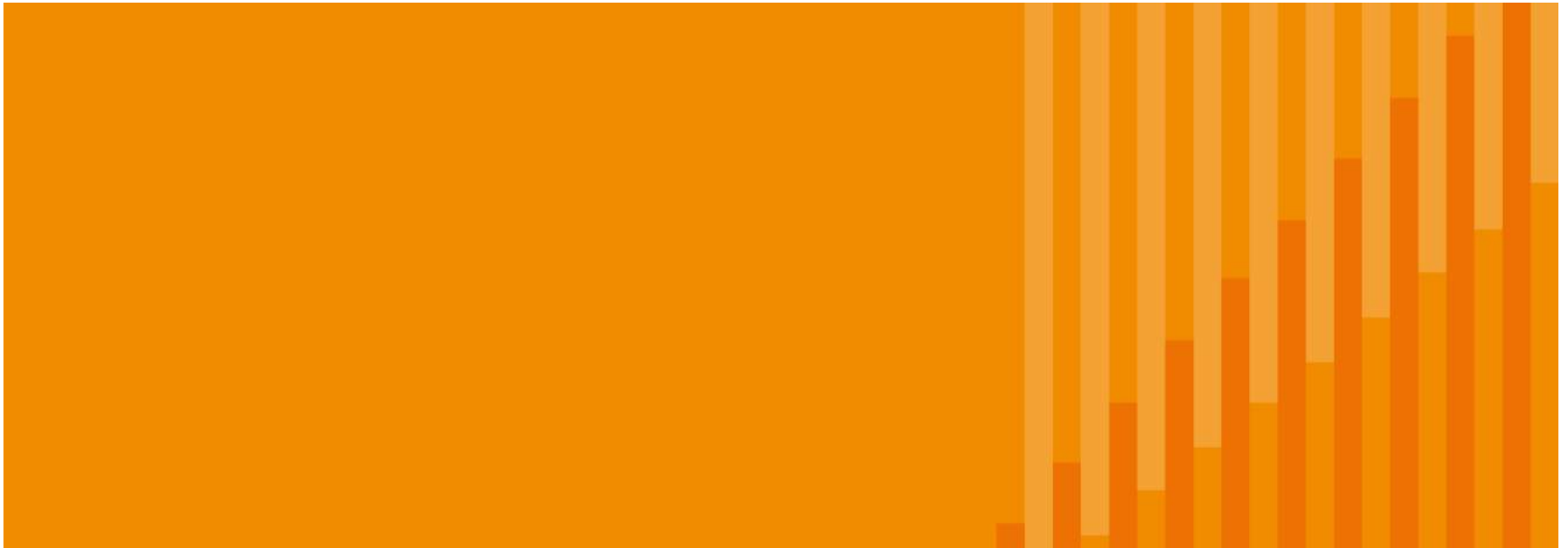

Design and Analysis (HRC)

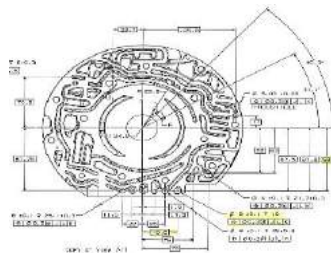
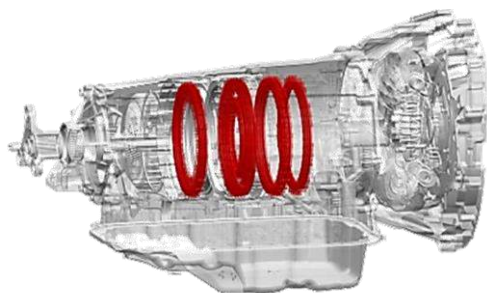

In close cooperation with our customers and suppliers, we develop and optimize parts and systems using modern CAE-supported approaches. Our quality and cost-oriented engineering is supported by a wide range of simulation tools.

Design office : 10 workstations (PTC Creo, NX, Catia)

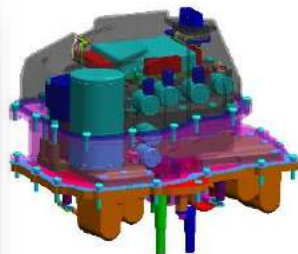
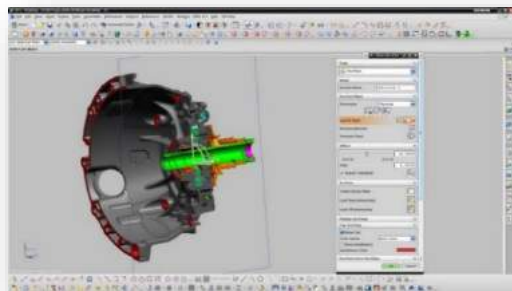

New Product Design – Complete Systems
Assemblies – Packaging studies – Rapid
Prototyping – Simultaneous Engineering –
Advanced Manufacturing.

Design and Analysis (cont.)

FEA and Fluid Dynamics

Park system engagement

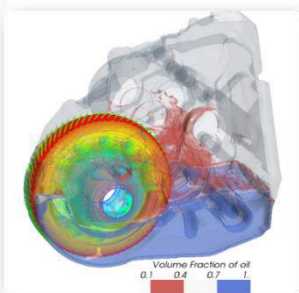
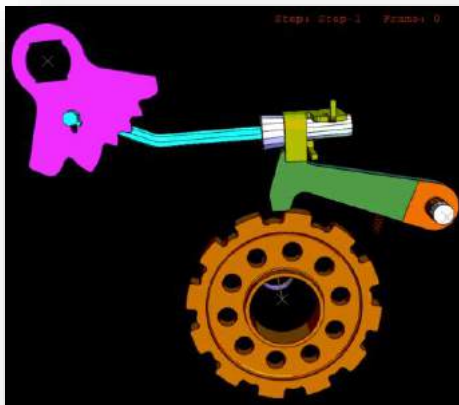

Lubrication and oil splashing

Powertrain bending analysis

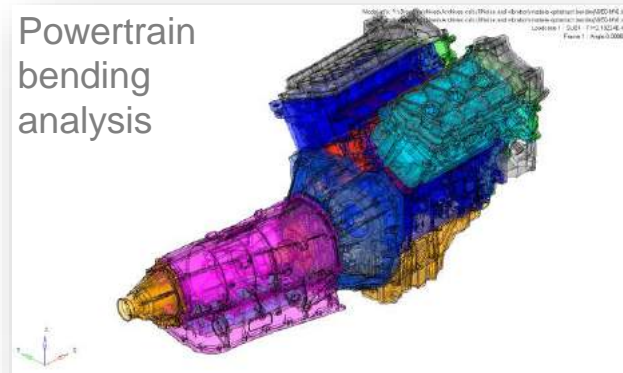

Sealing analysis

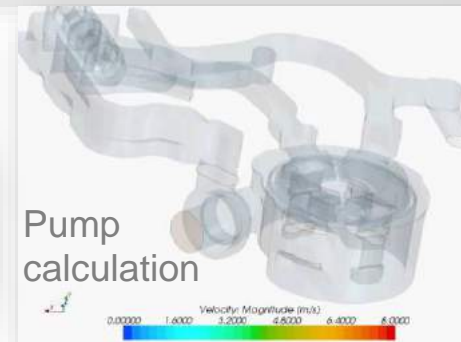
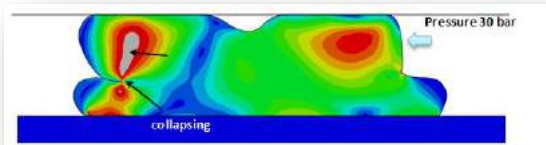

Pump calculation

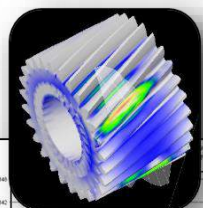

Gear analysis

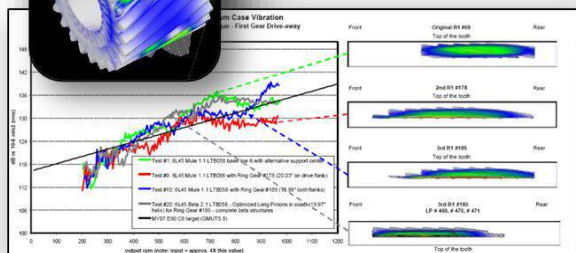

Clutch pack thermal analysis

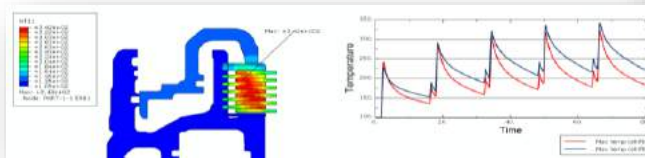

Design and Analysis (cont.)

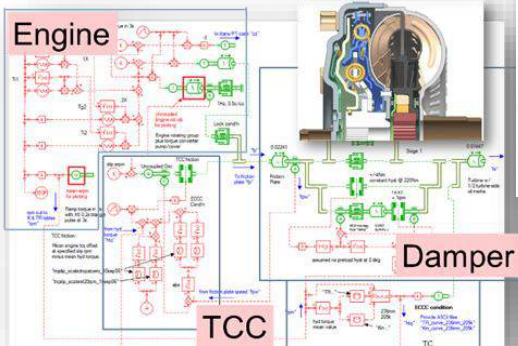
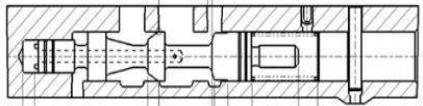

Patent application
FR1357357 –
25/07/2013

1D System Simulation

Mechatronics, lubrication, spin losses analysis, torsional vibration analysis, engine Start & Stop, vibrations, DOE.

Application Analysis

Fuel economy cycles, hybridization, top vehicle speed, grade ability, heat rejection, durability cycles.

Advanced Engineering

Study of market and competitors, standards and regulation follow-up, international symposiums, patent watch and IP management.

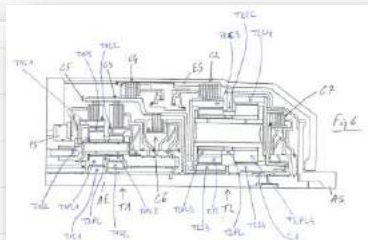
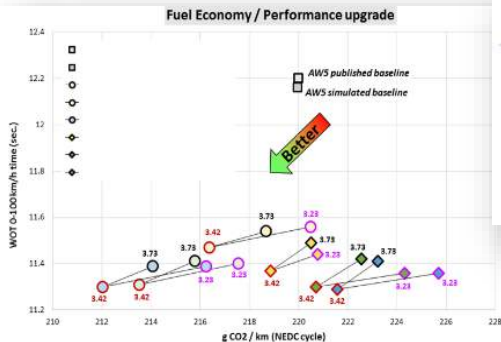

Team Innovation (advanced engineering)



Team Innovation (Future Projects)

Dedicated Hybrid Transmission (DHT)

- Within the study of DHT concept design, PUNCH Powerglide has already registered several patents
- This type of **hybrid transmission** is especially designed for hybrid vehicles. In order to reduce the cost, weight and footprint of the transmission, the number of speeds (5 for the combustion engine and 2 for the electric motor) is the strict minimum required to ensure optimum energy efficiency in each mode as well as driving performance and comfort equal to the current automatic gearboxes
- This **Dedicated Hybrid Transmission** concept will correspond to the second step towards hybridization, once the investment into new technology is justified by sufficient production volumes.

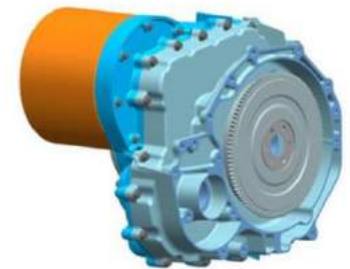
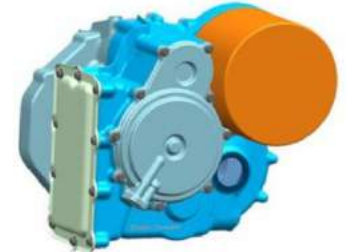

Team Innovation (Future Projects)

Transmission for Electric axles (e-drive)

- PUNCH Powerglide designs **e-drive** modules which include an electric motor with its control system and the power transmission and differential mechanical components. The **e-drive** concept represents a compact and fully integrated technical solution enabling a vehicle platform to be easily electrified
- This module can be used in hybrid or fully electric vehicles on the front or rear axle.

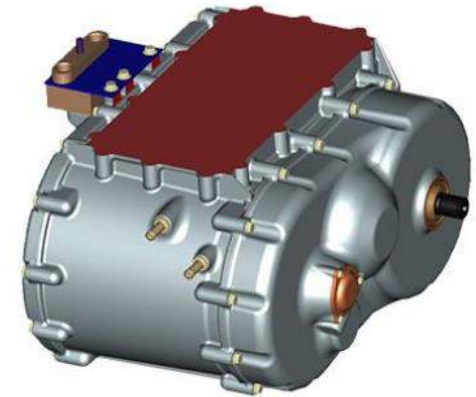

Test Facilities

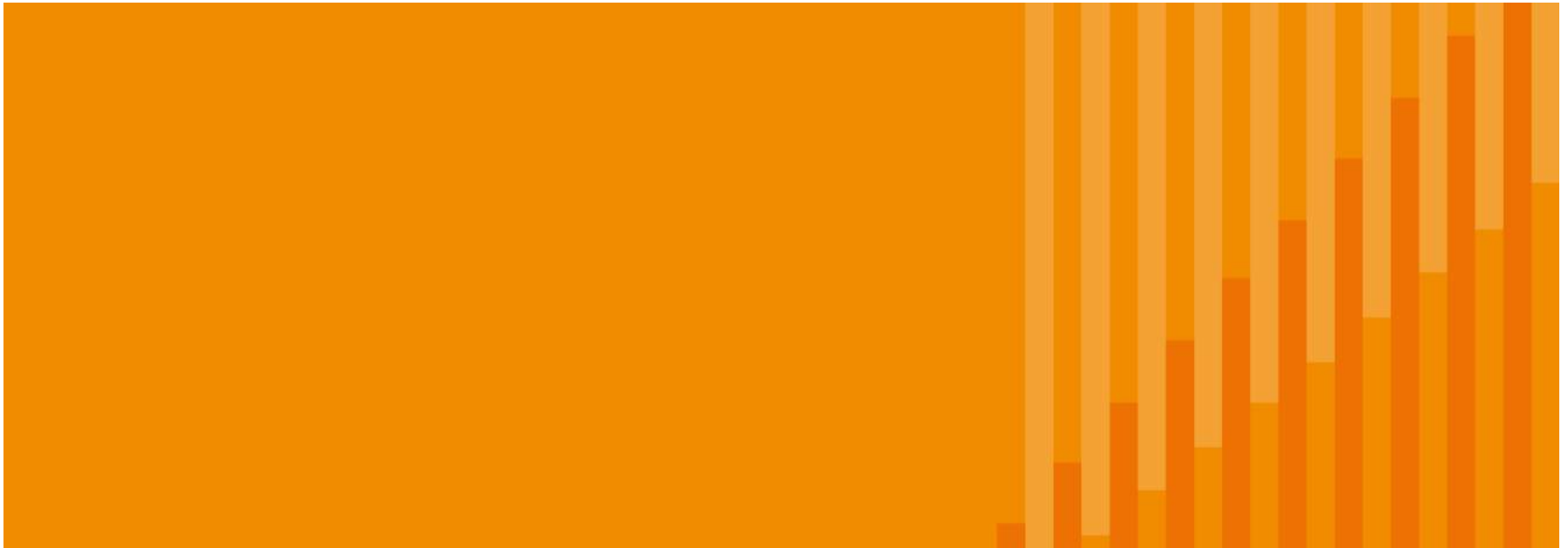

Test Facilities – Component Test Cells



The Technical Center includes a full range of testing equipment to ensure the development and the validation of automatic or manual transmissions.

Functional & Component Test Cells

- 3 spin rigs (without load)
- 2 hydraulic cycling test cells
- 1 Hydraulic pump test cell
- 1 Transmission climate chamber
- 1 Valve body cycling cell
- 1 Torsional test cell

In addition

- 1 climate chamber (54 m³ from -40°C to +50°C)
- 1 chassis dyno test cell.

Test Facilities – Dynamometer Test Cells



- Road Load simulation
- PUMA automation system.
- Early damage detection system.

- **Hybrid** capabilities / battery simulation (250kW).
- Motoring power up to 250 kW
- Output speeds up to 8 000 rpm (RWD) and 2 660 rpm (FWD)

7 Dynamometer Test Cells

Scope : development and durability testing

- **Two electrical dynamometer** test cells, including one with **hybrid** capabilities.
- **Three dynamometer test cells** equipped with two electrical engines for FWD or RWD transmissions (T configuration using rear vehicle axle), including two with **hybrid** capabilities
- **Two dynamometer test cells** equipped with a single electrical engine, used for RWD transmission, including one with **hybrid** capabilities.

Hybrid 

Test Facilities – Roller Test Bench, Cold Chamber & Special Test Conditions (slope, test track,...)



Climatic Chamber

- -40°C to +50°C
- 54m³

Chassis Dynamometer

- Max 135km/h, 87kW
- Tractive effort 1500N
- Inertia 453 to 2950kg

Hill slope

- 20%
- 30%.

Test Facilities – Garage and Workshops



Garage and Workshops

- **15 hoists (3.5 T and 4 T)** for car conversion, car fleet maintenance, calibration and development support
- **4 private bays**
- **About 30 work stations** for prototypes assembling, tear-down and upgrading, end of test analysis, quality control.

Test Facilities - Noise and Vibration Laboratory

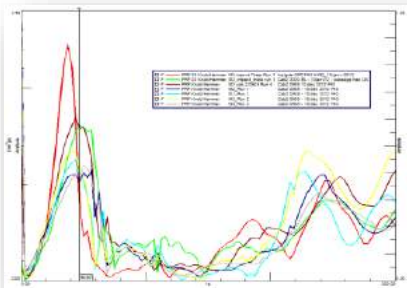

Experimental Structural Analysis

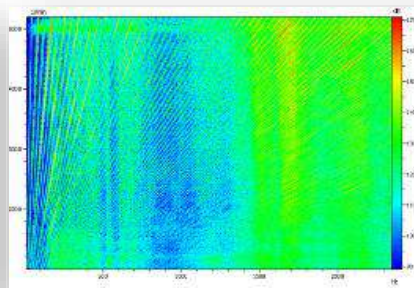

Spectral Map

Our scope of work ranges from **NVH benchmark and measurements on vehicles and test benches**, frequency-based analysis, experimental modal analysis, rotary machine expertise, torsional vibration analysis, sound intensity measurement, sound power calculation

- **5 NVH dedicated acquisition systems** from LMS & Müller-BBM
- More than **150 sensors**: accelerometers, microphones, acoustic head, shaker, impact hammer, ...



Acoustic Head



Measurement on Test Cells

Software and Calibration

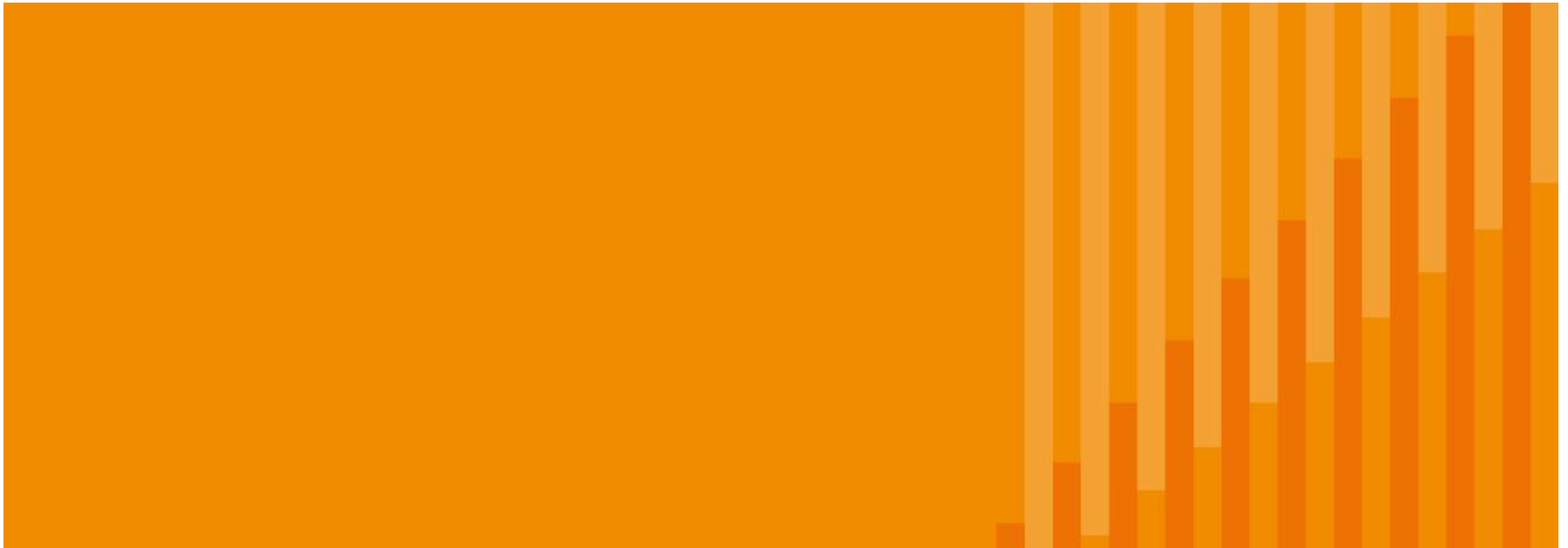

Software and Calibration



Calibration Group

In the specific area of automatic transmission, our calibration expertise consists in setting the parameters of the transmission control unit. The targets are to :

- **Find the best drivability** compromise for each driving mode: Economy, Sport & Manual Mode
- **Ensure optimal shift quality**
- **Provide the optimal vehicle performance** by finding the best match between the engine and the gearbox
- **Reduce fuel consumption and emissions.**

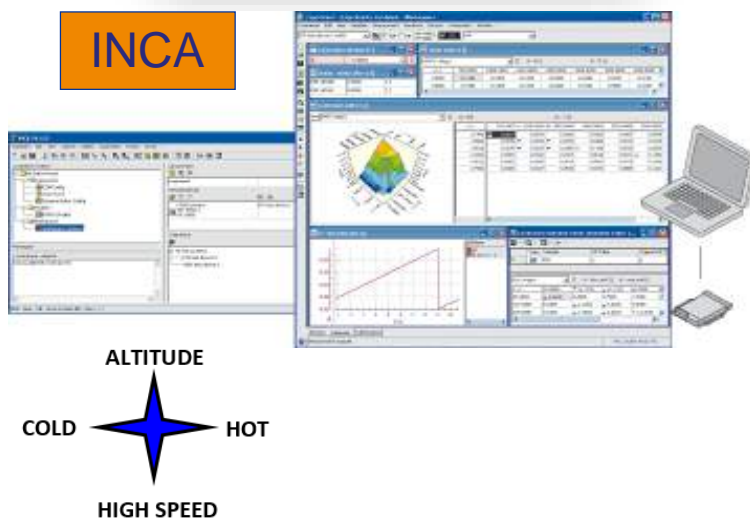

Software and Calibration (cont.)

Embedded Software



This group is in charge of the embedded software development for automatic transmissions throughout the complete software life cycle, from the customer requirements to the final customer software delivery, covering the complete range of software specialties :

- Platform experts for the **On-Vehicle communication**: CAN, ...
- Experts for the **Off-Vehicle communication**: Flash Programming, UDS, KWP, ...
- **Algorithm development** for the transmissi control using C code, Matlab/Simulink, ...
- **Diagnostics & OBD**
- **HIL Validation** (DSPACE / 5 HIL benches in use)
- **Functional Safety.**

Project Management

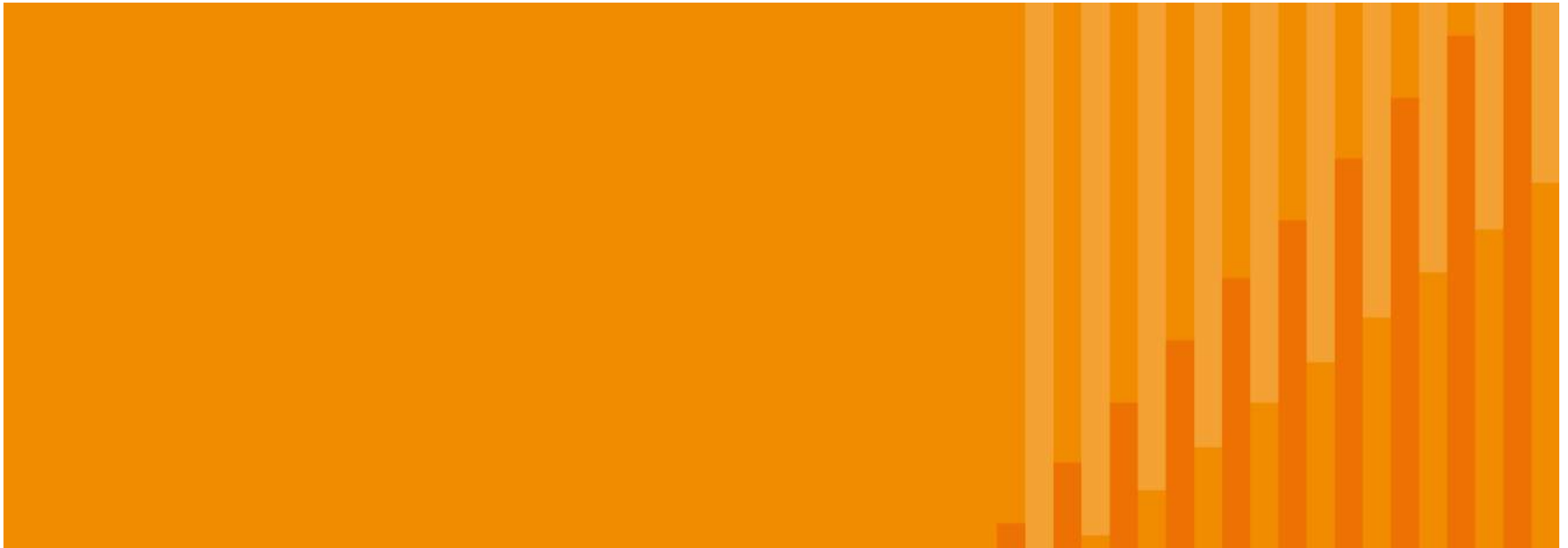

Project Management



Assistant Chief Engineers

- Responsible for driving one product development (ensures that STC deliverables for his/her product line are met)

Application Engineers

- Specialists in touch with the customer for product integration in vehicles.

Strasbourg Technical Center – Experience

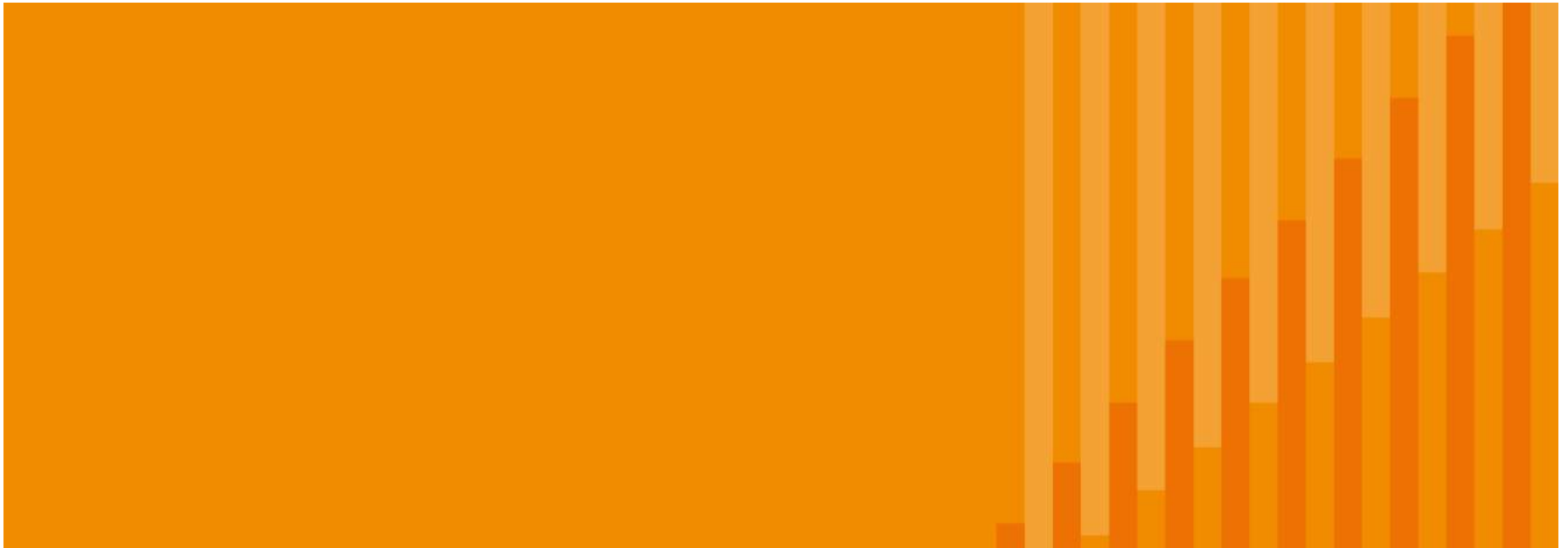

STC Experience: > 100 Engineers and Technicians



Automatic transmission

- RWD 6 & 8 speeds
- FWD 6 speeds



Manual transmission and MTA



Transfer box (PTU)



Other projects:

Starting clutch, Start&Stop



DCT, FWD 8-speed TRS, CVT

Scope of Work - Engineering



- **Application engineering 6L50**
- **New development**
 - 6L Mild Hybrid, 6LP2 full hybrid
 - New products (eDrive, DHT,...)
- **Internal customers** (quality assurance, process changes,...)
- **External customers** (Engineering services)
- **Benchmark studies**

PUNCH Powerglide Services

Product and Customer Portfolios

PUNCH Powerglide offers services to OEMs and Automotive Suppliers

- | | |
|---|---|
| <ul style="list-style-type: none"> • Consulting and Project Management • Design and Analysis • Software and Calibration • Test Facilities <ul style="list-style-type: none"> • Component Test Benches • Dynamometer Test Benches • Garage and Tool Room | <ul style="list-style-type: none"> • Laboratories <ul style="list-style-type: none"> • Noise and Vibration Laboratory • Instrumentation Laboratory • Material Laboratory • Metrology Laboratory • Manufacturing Engineering Process <ul style="list-style-type: none"> • Aluminum Die Cast Process • Lean Manufacturing |
|---|---|



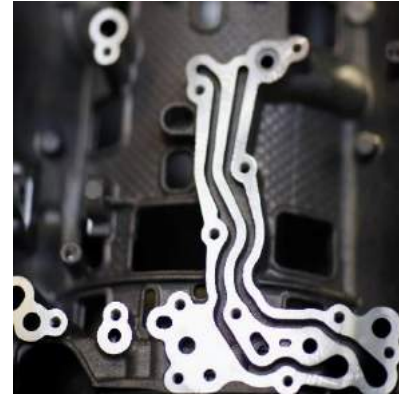

PUNCH | Powerglide

81, rue de La Rochelle
67026 Strasbourg Cedex, France
sales@punchpowerglide.com

+33 3 88 55 88 55

punchpowerglide.com

